

USER GUIDE & INSTALLATION INSTRUCTIONS

900 Deluxe Induction G5

SLOW BAKED LEG OF LAMB



INGREDIENTS

- 2–3 large sprigs of rosemary
- 4 large garlic cloves cut in half lengthways
- 1.8 kg leg of lamb
- 8 good quality anchovy fillets, halved
- 100 ml olive oil
- 250 ml dry red wine
- Maldon salt and freshly ground black pepper

METHOD

1. Preheat the oven to 220 °C (for a conventional oven), 200 °C (for a fan oven) or gas mark 7.
2. Pull the small sprigs off the rosemary branches and set aside with the garlic.
2. Using the tip of a paring knife, make up to 20 well-spaced cuts into the flesh of the lamb, about 2.5 cm inch deep. Divide the rosemary sprigs, garlic and anchovies and push down into the cuts. Place the leg on a large roasting tin and pour over the oil, massaging it all over the joint. Season well with salt and pepper and pour the wine and 250 ml water into the tin.
3. Put into the oven and sear for 15 minutes, then turn the temperature right down to 130 °C (conventional oven), 110 °C (fan oven) or gas mark 1 and roast for 4–5 hours, basting every 30 minutes or so. Basting frequently helps to keep the meat moist and encourages the build up of a good glaze on the outside. Add more liquid (wine or water) if the tin looks dry – there should always be liquid in the tin throughout this cooking process.
4. The meat is ready when it starts to fall off the bone, at which point it should have a core temperature of 90 °C. Remove from the oven, transfer to a warmed carving dish, cover loosely with foil and leave to rest in a warm place for 30–45 minutes before carving.
5. Pour the juices from the tin into a tall hi-ball glass and allow to settle. Spoon the fat from the top of the glass. There should be enough sticky, reduced juices for an intense gravy hit – if not, pour the juices you have back into the roasting tin and put it over the heat, pour in a splash of water or wine and deglaze the tin scraping up all the sticky bits from the base. Boil fast until syrupy, taste and correct the seasoning.

RASPBERRY SOUFFLÉ...



INGREDIENTS

- 400 g raspberries
- 1 tbsp lemon juice
- 100 g caster sugar
- 2 tsp crème de framboise
- 1 tsp cornflour
- 180 g egg whites (about 6)
- Pinch of cream of tartar or a squeeze of lemon juice
- Icing sugar for dusting

METHOD

1. For the soufflé, press the raspberries through a fine sieve to produce 180 g of purée. Put this into a heavy-bottomed pan, add the lemon juice and reduce down to a thick jam, stirring from time to time and being careful not to let it catch and burn.
2. Put 45 g of the sugar in a separate pan. Melt it and then boil until it becomes a thick syrup (121 °C on a sugar thermometer). To test without a thermometer, dip a teaspoon into the syrup and then dip quickly into cold water. You should be able to roll the cooling syrup into a ball between your fingers. Be careful as the syrup is extremely hot. When it has reached the right point, stir the hot syrup into the raspberry jam.
3. Mix the framboise and cornflour together and stir into the jam over the heat. Turn the jam into a small bowl, sprinkle the surface with icing sugar and cover with cling film.
4. Preheat the oven (not grill) to 180 °C shelf level 2 (conventional oven), 160 °C (fan oven) or gas mark 4 centre shelf.
5. Whisk the egg whites with the cream of tartar until you can form soft peaks, then fold in the remaining caster sugar. Lightly fold the whites into the jam, leaving thin traces of white visible in the mixture.
6. Spoon into four large buttered and sugared ramekins, place these on a baking tray and bake for 10 minutes.
7. Dust with icing sugar.

Contents

1. Before You Start...	1	6. Troubleshooting	16
Installation and Maintenance	1	7. Installation	18
Peculiar Smells	1	Dear Installer	18
Ventilation	1	Safety Requirements and Regulations	18
Personal Safety	1	Provision of Ventilation	18
Hob Care	3	Location of Cooker	18
Cooker Care	3	Positioning the Cooker	19
2. Overview	4	Moving the Cooker	19
The Hob	4	Fitting the Stability Bracket	20
Operating the Oven	9	Repositioning the Cooker Following Connection	20
Accessories	9	Levelling	20
3. Cooking Tips	10	Electrical Connection	21
Using Your Induction Cooker	10	Final Checks	21
General Oven Tips	10	Fitting the Plinth	21
4. Cooking Table	11	Customer Care	21
5. Cleaning Your Cooker	12	8. Circuit Diagrams	22
Hob	12	Circuit Diagram: Hob	22
Glide-out Grill	13	Circuit Diagram: Oven	23
Control Panel and Oven Doors	14	9. Technical Data	24
Ovens	14	10. Warranty/After Sales Service	25
The Tall Oven	14	If You Have a Problem	25
Cleaning Table	15	Notes	25
		Out of Warranty	25
		Spare Parts	25

1. Before You Start...

Thank you for buying this cooker. It should give you many years of trouble-free cooking if installed and operated correctly. It is important that you read this section before you start, particularly if you have not used an induction cooker before.

⚠ This appliance is designed for domestic cooking only. Using it for any other purpose could invalidate any warranty or liability claim. In particular, the oven should NOT be used for heating the kitchen – besides invalidating claims this wastes fuel and may overheat the control knobs.

Installation and Maintenance

All installations must be in accordance with the relevant instructions in this booklet, with the relevant national and local regulations, and with the local electricity supply companies' requirements.

Make sure that the cooker is correctly wired and switched on.

The hob control display will flash for about 2 seconds during the first power setting – this is normal.

Only a qualified service engineer should service the cooker, and only approved spare parts should be used.

Always allow the cooker to cool and then switch it off at the mains before cleaning or carrying out any maintenance work, unless specified otherwise in this guide.

Peculiar Smells

When you first use your cooker it may give off an odour. This should stop after use.

Before using your cooker for the first time, make sure that all packing materials have been removed and then, to dispel manufacturing odours, turn all the ovens to 200 °C and run for at least an hour.

Before using the grill for the first time you should also turn on the grill and run for 30 minutes with the grill pan in position, pushed fully back, and the grill door open.

Make sure the room is well ventilated to the outside air (see 'Ventilation' below). People with respiratory or allergy problems should vacate the area for this brief period.

Ventilation

⚠ CAUTION: The use of a cooking appliance results in the production of heat and moisture in the room in which it is installed. Therefore, make sure that the kitchen is well ventilated: keep natural ventilation holes open or install a powered cookerhood that vents outside. If you have several hotplates on, or use the cooker for a long time, open a window or turn on an extractor fan.

Personal Safety

Important information for pacemaker and implanted insulin pump users: The functions of this hob comply with the applicable European standards on electromagnetic interference. If you are fitted with a pacemaker or implanted insulin pump and are concerned please consult your doctor for medical advice.

⚠ DO NOT modify this appliance.

⚠ This appliance can be used by children aged from 8 years and above and persons with reduced physical, sensory or mental capabilities or lack of experience and knowledge if they have been given supervision or instruction concerning use of the appliance in a safe way and understand the hazards involved. Children shall not play with the appliance. Cleaning and user maintenance shall not be made by children without supervision.

⚠ WARNING!
The appliance and its accessible parts become hot during use and will retain heat even after you have stopped cooking. Care should be taken to avoid touching heating elements. Children less than 8 years of age shall be kept away unless continuously supervised.

⚠ When the hob is in use keep magnetic items, such as credit and debit cards, floppy disk, calculators, etc. away.

⚠ CAUTION: A long term cooking process has to be supervised from time to time. A short term cooking process has to be supervised continuously.

⚠ Danger of fire: DO NOT store items on the cooking surfaces.

⚠ To avoid overheating, DO NOT install the cooker behind a decorative door.

⚠ Accessible parts will become hot during use and will retain heat even after you have stopped cooking. Keep babies and children away from the cooker and never wear loose-fitting or hanging clothes when using the appliance.

⚠ DO NOT use a steam cleaner on your cooker.

Always be certain that the controls are in the OFF position when the oven is not in use, and before attempting to clean the cooker.

⚠ Take care when touching the marked cooking areas of the hob.

⚠ When the oven is on, DO NOT leave the oven door open for longer than necessary, otherwise the control knobs may become very hot.

⚠ When using the grill, make sure that the grill pan is in position and pushed fully in, otherwise the control knobs may become very hot.

Fig.1-1

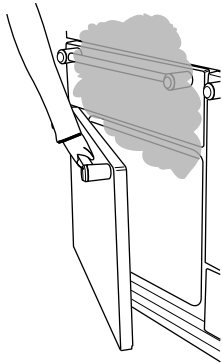
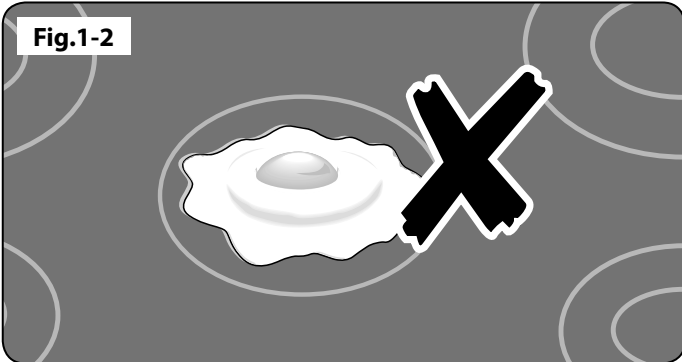

Fig.1-2



Always keep combustible materials, e.g. curtains, and flammable liquids a safe distance away from your cooker.

⚠ DO NOT spray aerosols in the vicinity of the cooker while it is on.

Cooking high moisture content foods can create a 'steam burst' when an oven door is opened (**Fig.1-1**). When opening an oven stand well back and allow any steam to disperse.

Use dry oven gloves when applicable – using damp gloves might result in steam burns when you touch a hot surface. Do not use a towel or other bulky cloth in place of a glove – it might catch fire if brought into contact with a hot surface.

⚠ NEVER operate the cooker with wet hands.

⚠ DO NOT use aluminium foil to cover shelves, linings, the oven roof or the oven base.

⚠ NEVER heat unopened food containers. Pressure build up may make the containers burst and cause injury.

⚠ DO NOT use unstable saucepans. Always make sure that you position the handles away from the edge of the hotplate.

Never leave the hotplate unattended at high heat settings. Pans boiling over can cause smoking, and greasy spills may catch on fire. Use a deep fat thermometer whenever possible to prevent fat overheating beyond the smoking point.

⚠ WARNING!
Unattended cooking on a hob with fat or oil can be dangerous and may result in fire.

⚠ NEVER leave a chip pan unattended. Always heat fat slowly, and watch as it heats. Deep fry pans should be only one third full of fat. Filling the pan too full of fat can cause spill over when food is added. If you use a combination of oils or fats in frying, stir them together before heating, or as the fats melt.

Foods for frying should be as dry as possible. Frost on frozen foods or moisture on fresh foods can cause hot fat to bubble up and over the sides of the pan. Carefully watch for spills or overheating of foods when frying at high or medium high temperatures. Never try to move a pan of hot fat, especially a deep fat fryer. Wait until the fat is cool.

Do not use the top of the flue (the slots along the back of the cooker) for warming plates, dishes, drying tea towels or softening butter.

⚠ DO NOT use water on grease fires and never pick up a flaming pan. Turn off the controls and then smother a flaming pan on a surface unit by covering the pan completely with a well fitting lid or baking tray. If available, use a multi-purpose dry chemical or foam-type fire extinguisher.

Take care that no water seeps into the appliance.

⚠ This appliance is heavy so take care when moving it.

⚠ NEVER allow anyone to climb or stand on the hob.

Hob Care

⚠ NEVER cook directly on the hob surface (Fig.1-2).

⚠ DO NOT use the hob surface as a cutting board.

DO NOT leave utensils, foodstuffs or combustible items on the hob when it is not in use (e.g. tea towels, frying pans containing oil).

⚠ DO NOT place plastic or aluminium foil, or plastic containers, on the hob.

⚠ DO NOT leave the hob zones switched on unless being used for cooking.

DO NOT stand or rest heavy objects on the hob. Although the ceramic surface is very strong, a sharp blow or sharp falling object (e.g. a salt cellar) might cause the surface to crack or break (Fig.1-3).

⚠ Should a crack appear in the surface, disconnect the appliance immediately from the supply and arrange for its repair.

Always LIFT pans off the hob. Sliding pans may cause marks and scratches (Fig.1-4). Always turn the control to the OFF position before removing a pan.

⚠ Take care when placing hot lids onto the hob surface. Lids that have been covering boiling or steaming foods can 'stick' to the ceramic glass. Should this occur, DO NOT attempt to lift the lid off the hotplate: this may damage the hob surface.

DO NOT place anything between the base of the pan and the hob surface (e.g. asbestos mats, aluminium foil, wok stand).

Cooker Care

As steam can condense to water droplets on the cool outer trim of the oven, it may be necessary during cooking to wipe away any moisture with a soft cloth. This will also help to prevent soiling and discolouration of the oven exterior by cooking vapours (Fig.1-5).

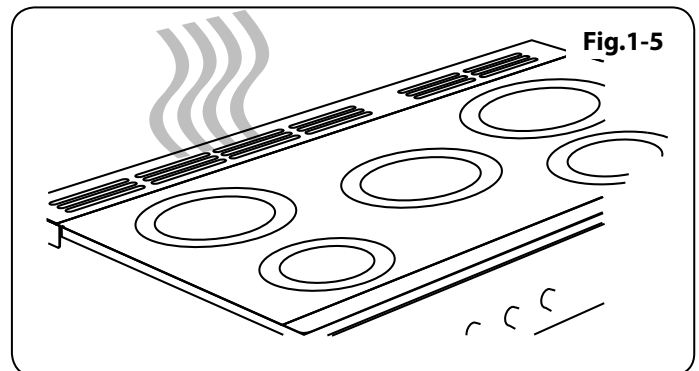
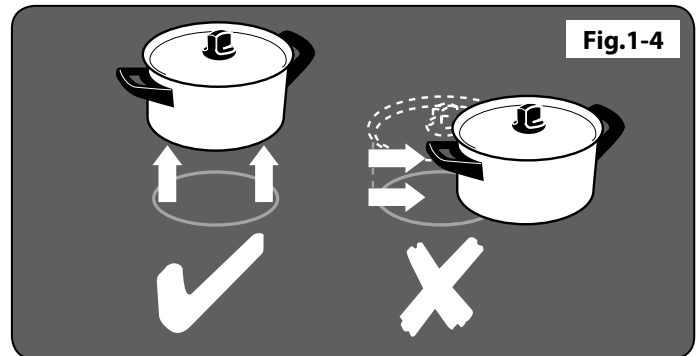
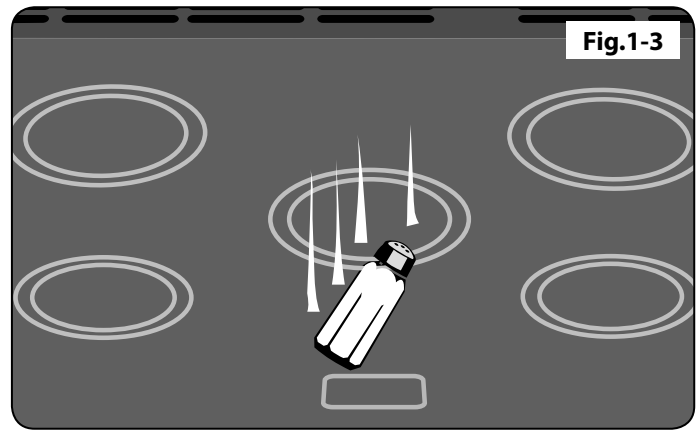

2. Overview

Fig.2-1

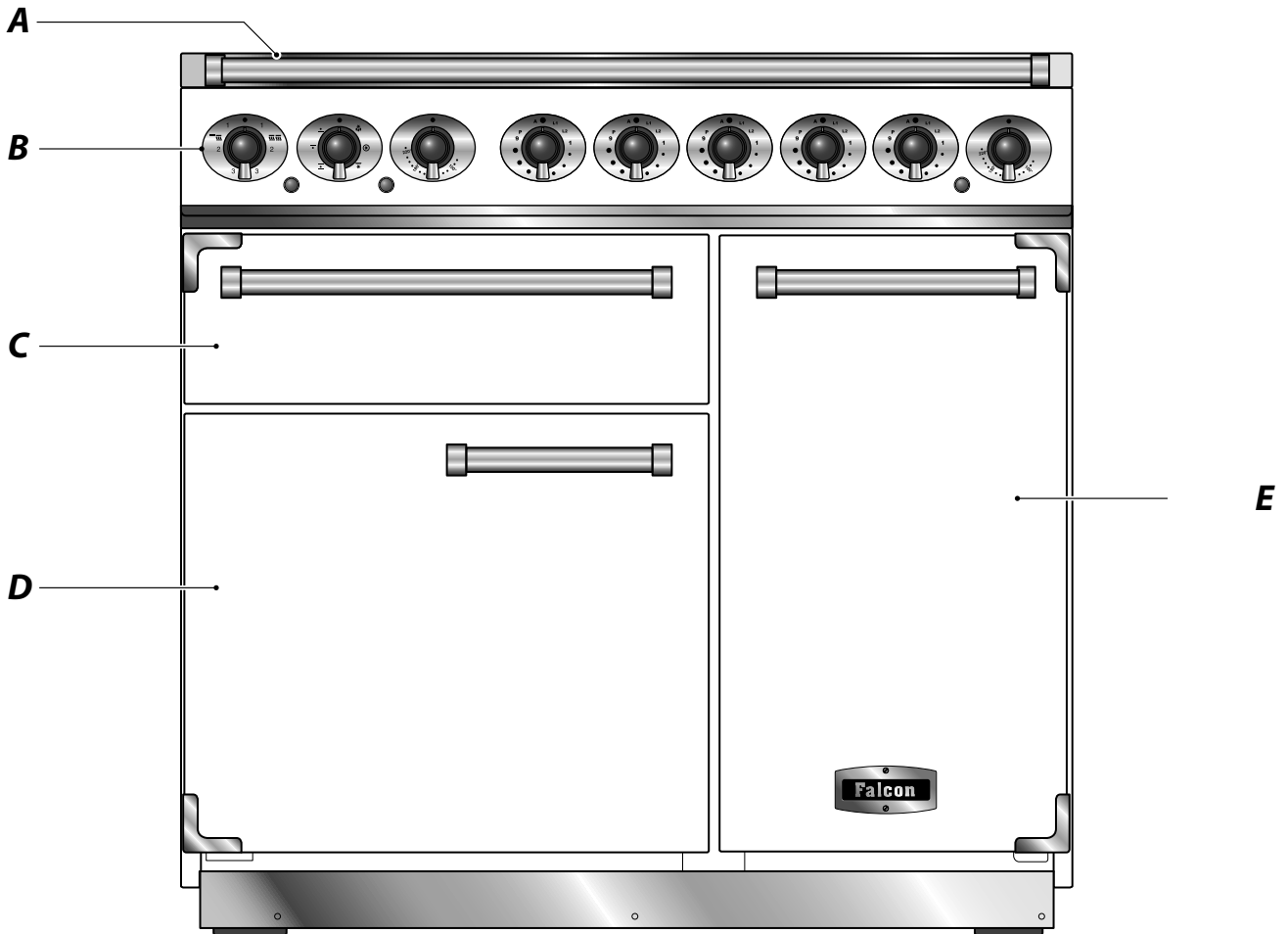
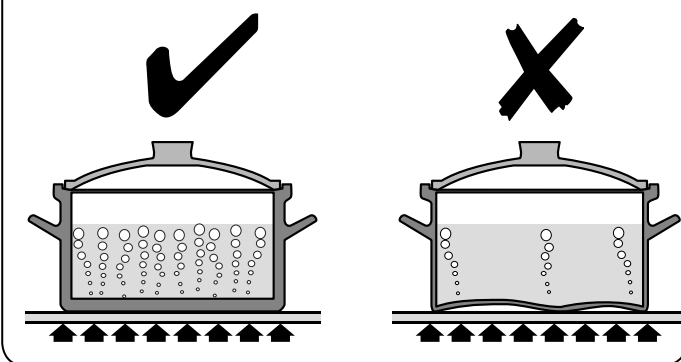

Fig.2-2



The Falcon induction cooker (**Fig.2-1**) has the following features:

- A.** 5 induction cooking zones
- B.** A control panel
- C.** A glide-out grill
- D.** Main multi-function oven
- E.** Tall fan oven

The Hob

Use only pans that are suitable for induction hobs. We recommend stainless steel, enamelled steel pans or cast iron pans with enamelled bases. Note that some stainless steel pans are not suitable for use with an induction hob so please check carefully before purchasing any cookware.

Pans made of copper, aluminium or ceramic are not suitable for use on an induction hob. *The kind of pan you use and the quantity of food affects the setting required. Higher settings are required for larger quantities of food.*

Pots and pans should have thick, smooth, flat bottoms (**Fig.2-2**). This allows the maximum heat transfer from the hob to the pan, making cooking quick and energy efficient.

Never use a round-bottomed wok, even with a stand.

The very best pans have bases that are very slightly curved up when cold (**Fig.2-3**). If you hold a ruler across the bottom you will see a small gap in the middle. When they heat up the metal expands and lies flat on the cooking surface.

Make sure that the base of the pan is clean and dry to prevent any residue burning onto the hob panel. This also helps prevent scratches and deposits.

Always use pans that are the same size as (or slightly larger than) the areas marked on the hob. Using a lid will help the contents boil more quickly.

⚠ Always take care before touching the surface, even when the hob is turned off. It may be hotter than you think!

The induction hob comprises of five cooking zones (**Fig.2-4**) containing induction elements with different ratings and diameters each with a pan detector and residual heat indicator, and a hob control display.

The hob control display (**Fig.2-5**) informs you of the following induction hob functions:

- ☒ Pan Detector
- H Residual Heat Indicator
- R Automatic Heat-up
- ☒ Child Lock
- L1/L2 Low Temperature Setting
- P Power Boost Setting

Pan Detector, ☒

IMPORTANT: After use, switch off the hob element by its control and **DO NOT RELY** on the pan detector.

If a cooking area is switched on and there is no pan in place or if the pan is too small for the cooking area, then no heat will be generated. The symbol ☒ will appear on the hob control display; this is the “pan-missing symbol”. Place a pan of the correct size on the cooking area and the ☒ symbol will disappear and cooking can begin. After 10 minutes without detecting a pan the cooking zone will switch off automatically.

Table 2-1 shows the minimum pan sizes recommended for each cooking zone.

Note: Using pans with a base diameter smaller than those recommended will result in a power reduction.

Residual Heat Indicator, H

After use, a cooking zone will remain hot for a while as heat dissipates. When a cooking zone is switched off the residual heat indicator symbol [H], will appear in the display. This shows that the cooking zone temperature is above 60 °C and may still cause burns. Once the temperature has dropped to below 60 °C the [H] will go out.

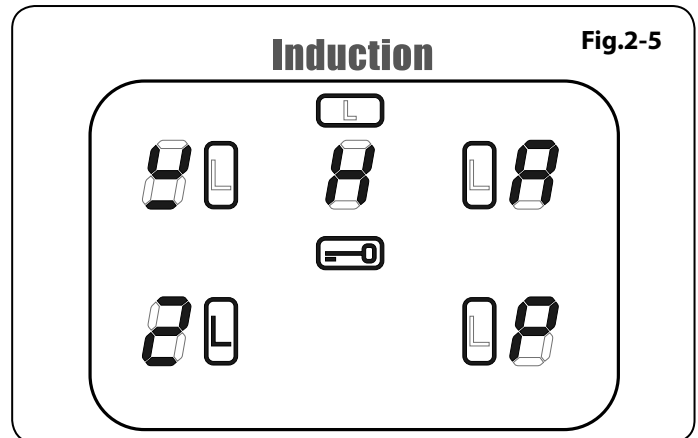
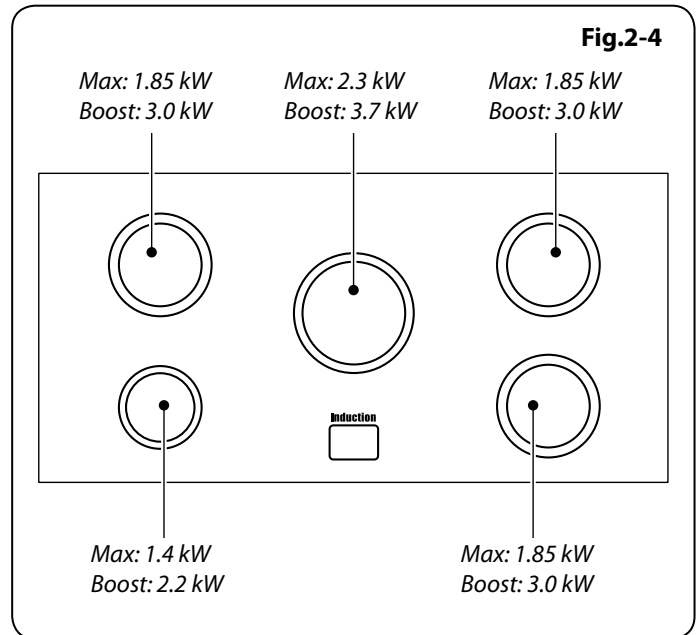
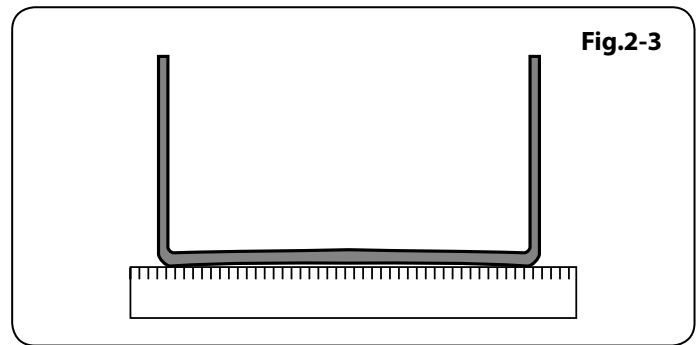

Cooking Zone	Minimum Pan Diameter (Pan Base) mm
Front left	140
Rear left	180
Centre	180
Rear right	180
Front right	140

Table 2-1

Power Level	Automatic Heat-up Time at 100% (min:sec)
1	0:48
2	2:24
3	3:50
4	5:12
5	6:48
6	2:00
7	2:48
8	3:36
9	

Table 2-2

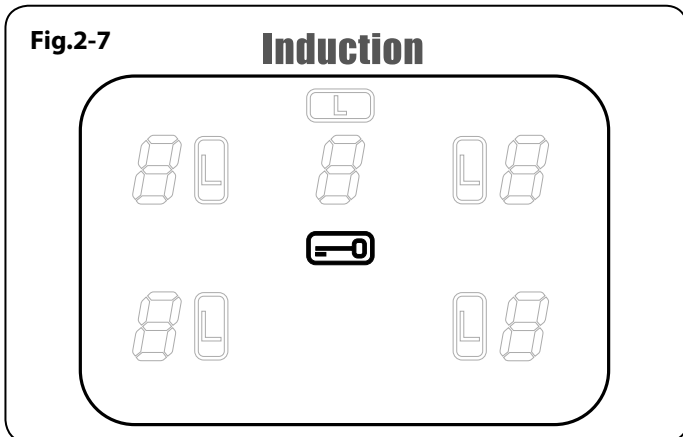
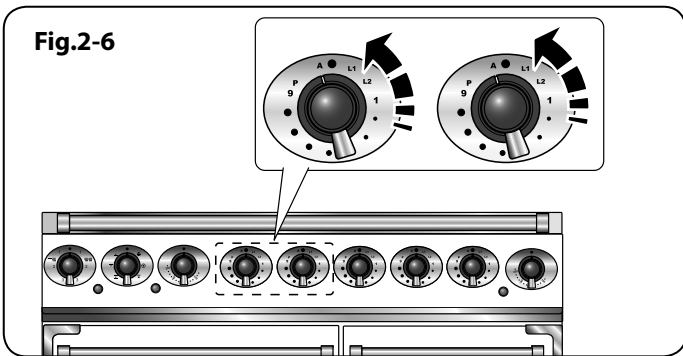

Power Level	Maximum Operating Time
L1 and L2	2 hours
1	6 hours
2	6 hours
3	5 hours
4	5 hours
5	4 hours
6	1.5 hours
7	1.5 hours
8	1.5 hours
9	1.5 hours
Power Boost	10 minutes

Table 2-3

Automatic Heat-up, *A*

This function is available on all of the cooking areas. It allows rapid heating up of the element to bring the selected cooking zone up to temperature. Once the zone is at the required cooking temperature the power level will reduce automatically to the preset level.

The function is selected by turning the control knob to the 'A' position. This can be selected by either turning the control knob momentarily counter-clockwise from the zero position or clockwise past the '9' until the symbol [A] is shown on the hob control display. Once the [A] is displayed, turn the control knob to the level of your choice (1 to 9). The pan will heat up at 100% power for a specified time before the power is reduced to the level selected.

When the Automatic Heat-up function is activated, the hob control display will alternately flash between the [A] setting and the chosen power level.

Once the Automatic Heat-up time has ended the hob control display will stop flashing and will display the chosen power level. The Automatic Heat-up function can be stopped by either turning the control knob back to the '0' power setting or turning the control knob to the '9' power setting. For your guidance **Table 2-2** shows the time available at 100% power depending on the power level selected in the Automatic Heat-up mode.

Child Lock,

IMPORTANT: The child lock can only be activated when all the cooking zones are switched off.

To prevent the unwanted use by children, the hob can be locked.

To lock the hob, simultaneously turn the two left-hand hob controls counter-clockwise (**Fig.2-6**) and hold until the  symbol appears in the centre of the hob control display (**Fig.2-7**).

Note: [A] will flash when locking the hob – this is normal.

Locking the hob will NOT affect the oven; it can still be used.

To unlock the hob, simultaneously turn the two left-hand hob controls counter-clockwise and hold until the  symbol disappears from the centre of the hob control display.

Low Temperature Setting, L1/L2

Each cooking area is equipped with 2 low temperature settings:

- L1 will maintain a temperature of about 40°C – ideal for gently melting butter or chocolate.
- L2 will maintain a temperature of about 90°C – ideal for simmering (bring the pan to the boil and then select L2 to keep soups, sauces, stews, etc at an optimal simmer).

The maximum time this setting can be used is 2 hours, after which the hob will switch off automatically. If required, you can immediately restart the Low Temperature function by reactivating L1 or L2. To increase the heat, just turn the control knob to the required level. The maximum times for all other power levels are shown in **Table 2-3**.

Power Boost Setting, P

All of the induction cooking zones have Power Boost available, activated by turning the control knob clockwise until [P] is shown on the hob control display.

Power Boost allows additional power to be made available for each of the cooking zones. This is useful to bring a large pan of water to the boil quickly.

The Power Boost function operates for a maximum of 10 minutes on each zone, after which the power is automatically reduced to setting 9.

When using the Power Boost function, the cooking zones are linked.

Fig.2-8 shows the hob layout. Zones A and B are linked together as are zones D and E.

This means that when using zone A on Power Boost and then switching zone B to Power Boost, the power to zone A will reduce slightly. The last zone switched to Power Boost always takes priority. Zones D and E work in the same way.

⚠ This is a built-in safety device.

Deactivate the Power Boost function by turning the control knob to a lower setting.

Overheat Function

This function identifies when the temperature of the pan rises rapidly and works to maintain a safe level of pan temperature. It should not interfere with normal cooking.

⚠ Please remember not to leave the hob unattended. Care should be taken to not allow your cookware to boil dry.

The Multi-function Oven

Multi-function ovens have an oven fan and oven fan element, as well as two extra heating elements. One element is in the top of the oven and the second is under the oven base. Take care to avoid touching the top element and element deflector when placing or removing items from the oven.

The multi-function oven has 3 main cooking functions: **fan**, **fan assisted** and **conventional cooking**. These functions should be used to complete most of your cooking.

The **browning element** and **base heat** can be used in the latter part of the cooking process to fine tune the results to your particular requirements.

Use **fanned grilling** for all your grilling needs and **defrost** to safely thaw small items of frozen food.

Table 2-4 gives a summary of the multi-function modes.

The multi-function oven has many varied uses. We suggest you keep a careful eye on your cooking until you are familiar with each function. Remember, not all functions will be suitable for all food types.

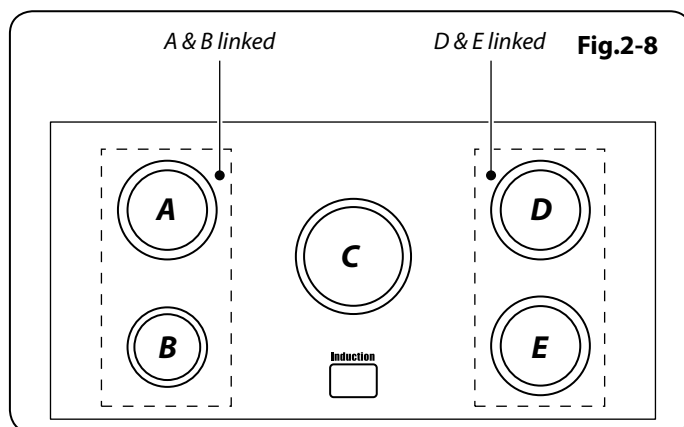

Function	Use
Defrost	To thaw small items in the oven without heat
Fan oven	A full cooking function, even heat throughout, great for baking
Fanned grilling	Grilling meat and fish with the door closed
Fan assisted	A full cooking function good for roasting and baking
Conventional oven	A full cooking function for roasting and baking in the lower half of the oven
Browning element	To brown and crisp cheese topped dishes
Base heat	To crisp up the bases of quiche, pizza or pastry

Table 2-4

Multi-function Oven Functions

Fan Oven



This function operates the fan and the heating element around it. An even heat is produced throughout the oven, allowing you to cook large amounts quickly.

Fan oven cooking is particularly suitable for baking on several shelves at one time and is a good 'all-round' function. It may be necessary to reduce the temperature by approximately 10°C for recipes previously cooked in a conventional oven.

If you wish to preheat the oven, wait until the indicator light has gone out before inserting the food.

Fanned Grilling



This function operates the fan while the top element is on. It produces a more even, less fierce heat than a conventional grill. For best results, place the food to be grilled, on a trivet over a roasting tin, which should be smaller than a conventional grill pan. This allows greater air circulation. Thick pieces of meat or fish are ideal for grilling in this way, as the circulated air reduces the fierceness of the heat from the grill.

The oven door should be kept closed while grilling is in progress, so saving energy.

You will also find that the food needs to be watched and turned less than for normal grilling. Preheat this function before cooking.

For best results we recommend that the grill pan is not located on the uppermost shelf.

Fan Assisted Oven



This function operates the fan, circulating air heated by the elements at the top and the base of the oven. The combination of fan and conventional cooking (top and base heat) makes this function ideal for cooking large items that need thorough cooking, such as a large meat roast.

It is also possible to bake on two shelves at one time, although they will need to be swapped over during the cooking time, as the heat at the top of the oven is greater than at the base, when using this function.

This is a fast intensive form of cooking; keep an eye on the food cooking until you have become accustomed to this function.

Conventional Oven (Top and Base Heat)



This function combines the heat from the top and base elements. It is particularly suitable for roasting and baking pastry, cakes and biscuits.

Food cooked on the top shelf will brown and crisp faster than on the lower shelf, because the heat is greater at the top of the oven than at the base, as in 'Fan Assisted Oven' function. Similar items being cooked will need to be swapped around for even cooking. This means that foods requiring different temperatures can be cooked together, using the cooler zone in the lower half of the oven and hotter area to the top.

The exposed top element may cook some foods too quickly, so we recommend that the food be positioned in the lower half of the oven to cook. The oven temperature may also need to be lowered.

Similar items being cooked will need to be swapped around for even cooking.

Browning Element



This function uses the element in the top of the oven only. It is a useful function for the browning or finishing of pasta dishes, vegetables in sauce, shepherds pie and lasagne, the item to be browned being already hot before switching to the top element.

Base Heat



This function uses the base element only. It will crisp up your pizza or quiche base or finish off cooking the base of a pastry case on a lower shelf. It is also a gentle heat, good for slow cooking of casseroles in the middle of the oven or for plate warming.

The Browning and Base Heat functions are useful additions to your oven, giving you flexibility to finish off items to perfection.

Defrost



This function operates the fan to circulate cold air only. Make sure the temperature control is at 0°C and that no heat is applied. This enables small items such as desserts, cream cakes and pieces of meat, fish and poultry to be defrosted.

Defrosting in this way speeds up the process and protects the food from flies. Pieces of meat, fish and poultry should be placed on a shelf, over a tray to catch any drips. Be sure to wash the shelf and tray after defrosting.

Defrost with the oven door closed.

Large items, such as whole chickens and joints should not be defrosted in this way. We recommend this be carried out in a refrigerator.

Defrosting should not be carried out in a warm oven or when an adjoining oven is in use or still warm. Make sure that dairy foods, meat and poultry are completely defrosted before cooking.

Operating the Oven

The multi-function oven has two controls: a function selector and a temperature setting knob (Fig.2-9).

Turn the function selector control to a cooking function. This is the fan oven setting (Fig.2-10).

Turn the oven temperature knob to the temperature you need. The oven heating light will glow until the oven has reached the temperature you selected. It will then cycle on and off during cooking as the oven maintains the selected temperature (Fig.2-11).

Your oven has many varied uses. We suggest you keep a careful eye on your cooking until you are familiar with each function. Remember, not all functions will be suitable for all food types.

Accessories

Oven Shelves – Left-hand (Main) Oven

In addition to the flat shelves, your cooker is supplied with a drop shelf (Fig.2-12). The drop shelf increases the possibilities for oven shelf spacing.

Removing and Refitting the Oven Shelves

The shelf has a small kink on either side (Fig.2-13). To remove the shelf, line these up with the stops in the shelf support (Fig.2-14). Lift the shelf upwards so that it will pass over the shelf stop (Fig.2-15) and then pull it forwards (Fig.2-16).

Refit in the reverse order, making sure to push it fully back.

Oven Shelves – Right-hand (Tall) Oven

The tall oven is supplied with four flat cooking shelves (Fig.2-17), and a plate-warming shelf (Fig.2-18).

When using the tall oven, you can cook on all four shelves at the same time, but make sure that they are well spaced out to allow the hot air to circulate.

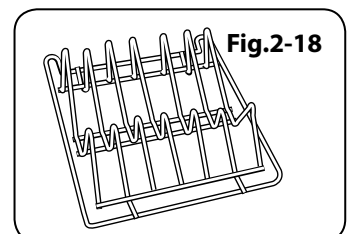
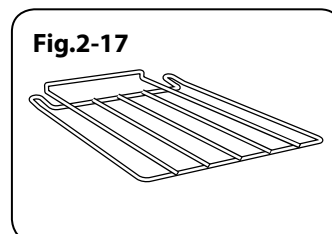
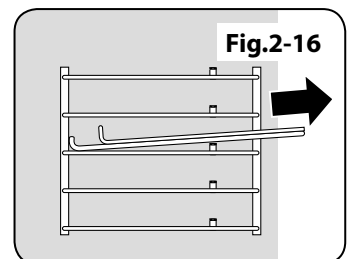
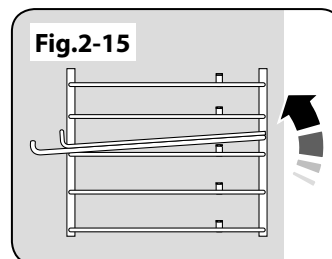
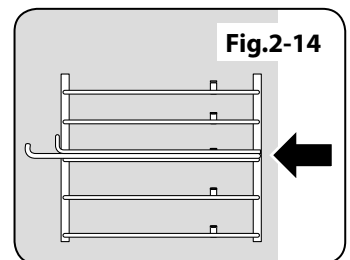
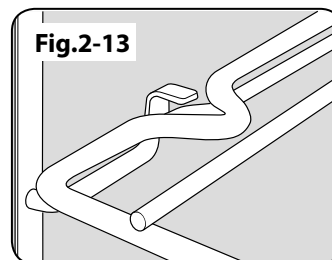
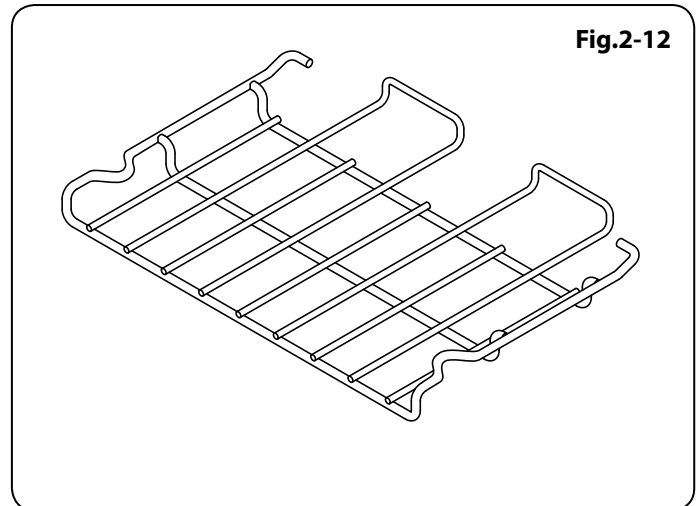
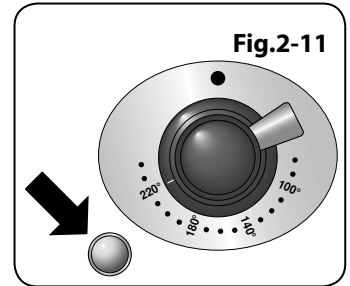
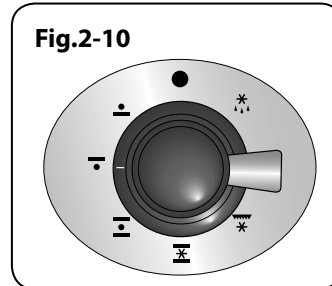
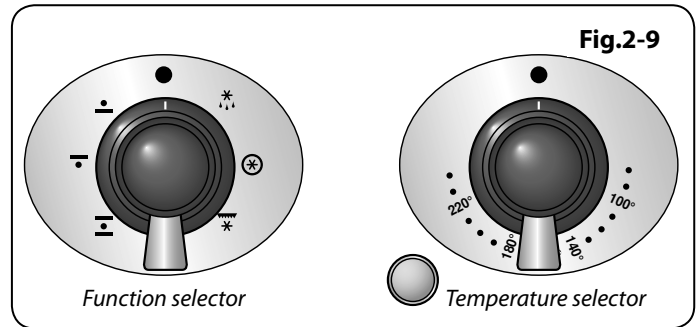

3. Cooking Tips

Using Your Induction Cooker

If you have not used an induction cooker before please be aware of the following:

- Make sure that the pans you have or buy are suitable for use on the induction hob. Stainless steel, enamelled steel or cast iron is ideal. Double check before you buy pans – they must have bases that would attract a magnet.
- Allow time to get used to induction cooking; it is fast and powerful as well as being gentle. When simmering, you may notice that liquids appear to stop bubbling and then start again almost immediately. This is perfectly normal.
- You may notice a faint vibrating sound coming from the pans when using the induction hob. Again, this is perfectly normal and will depend upon the type and style of pans you are using.
- The induction heating elements will phase on and off when cooking. Although an active cooking zone may appear to switch on and off, a constant heat is still being supplied to the base of the pan – this is completely normal.

General Oven Tips

The wire shelves should always be pushed firmly to the back of the oven.

Baking trays with food cooking on them should be placed level with the front edge of the oven's wire shelves. Other containers should be placed centrally. Keep all trays and containers away from the back of the oven, as overbrowning of the food may occur.

For even browning, the maximum recommended size of a baking tray is 340 mm (13½") by 340 mm (13½") in the main oven and 210 mm (9¹/₈") and 285 mm (12⁵/₈") in the tall oven.

When the oven is on, do not leave the door open for longer than necessary, otherwise the knobs may get very hot.

- Always leave a "finger's width" between dishes on the same shelf. This allows the heat to circulate freely around them.
- To reduce fat splashing when you add vegetables to hot fat around a roast, dry them thoroughly or brush lightly with cooking oil.
- Where dishes may boil and spill over during cooking, place them on a baking tray.
- The 'Cook & Clean' oven liners (see '*Cleaning Your Cooker*') work better when fat splashes are avoided. Cover meat when cooking.
- Sufficient heat rises out of the oven while cooking to warm plates in the grill compartment.
- If you want to brown the base of a pastry dish, preheat the baking tray for 15 minutes before placing the dish in the centre of the tray.

4. Cooking Table

The oven control settings and cooking times given in the table below are intended to be used **AS A GUIDE ONLY**. Individual tastes may require the temperature to be altered to provide a preferred result.

Food is cooked at lower temperature in a fan oven than in a conventional oven. When using recipes, reduce the fan oven temperature by 10 °C and the cooking time by 5-10 minutes. The temperature in the fan oven does not vary with height in the oven so you can use any shelf.

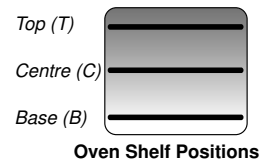

T - Top; C - Centre; B - Base

Food	Conventional Oven	Fan Oven	Approximate Cooking Time		
	Temperature °C (Shelf Position)	Temperature °C			
Meat					
Beef (no bone)	160 (C)	150	30-35 minutes per 500g +30-35 minutes.	<i>Thoroughly thaw frozen joints before cooking. Meat may be roasted at 220°C (210°C for fan oven) and the cooking time adjusted accordingly. For stuffed and rolled meats, add approximately 10 minutes per 500g, or cook at 200°C (190°C) for 20 minutes then 160°C (150°C) for the remainder.</i>	
	200 (C)	190	20-25 minutes per 500g +20-25 minutes.		
Lamb	160 (C)	150	30-35 minutes per 500g +30-35 minutes.		
	200 (C)	190	25-30 minutes per 500g +25-30 minutes.		
Pork	160 (C)	150	35-40 minutes per 500g +35-40 minutes.		
	200 (C)	190	25-30 minutes per 500g +25-30 minutes.		
Poultry					
Chicken	160 (C)	150	20-25 minutes per 500g +20-25 minutes.		<i>For stuffed poultry, you could cook at 200°C (190°C) for 20 minutes then 160°C (150°C) for remainder. Do not forget to include the weight of the stuffing.</i>
	200 (C)	190	15-20 minutes per 500g +15-20 minutes.		
Turkey	160 (C)	150	20 minutes per 500g +20 minutes.		
	200 (C)	190	15 minutes per 500g +15 minutes.		
Duck	160 (C)	150	25-30 minutes per 500g.	<i>For fresh or frozen prepacked poultry, follow instructions on the pack. Thoroughly thaw frozen poultry before cooking.</i>	
	200 (C)	190	20 minutes per 500g.		
Casserole	140-150 (C)	130-140	2-4 hours according to recipe.		
Yorkshire Pudding	220 (C)	210	Large tins 30-35 minutes; individual 10-20 minutes.		
Cake					
Very rich fruit - Christmas, wedding, etc.	140 (C/B)	130	45-50 minutes per 500g of mixture.	<i>Using the conventional oven: when two tier cooking leave at least one runner space between shelves. Position the baking tray with the front edge along the front of the oven shelf.</i>	
Fruit 180 mm tin	150 (C/B)	140	2-2½ hours.		
Fruit 230 mm tin	150 (C/B)	140	Up to 3½ hours.		
Madeira 180 mm	160 (C/B)	150	80-90 minutes.		
Queen cakes	190 (C/B)	180	15-25 minutes.		
Scones	220 (C/B)	210	10-15 minutes.		
Victoria sandwich				<i>Up to three tiers can be cooked in a fan oven at the same time but make sure to leave at least one runner space between each shelf being cooked on.</i>	
180 mm tin	180 (C/B)	170	20-30 minutes.		
210 mm tin	180 (C/B)	170	30-40 minutes.		
Desserts					
Shortcrust tarts	200 (C/B)	190	20-30 minutes on a preheated tray.	<i>Using the conventional oven: for even browning the maximum size of baking tray recommended is 340 mm x 340 mm. This ensures free heat circulation.</i>	
Fruit pies	200 (C/B)	190	35-45 minutes.		
Tartlets	200 (C/B)	190	10-20 minutes according to size.		
Puff pastry	210 (C/B)	200	20-40 minutes according to size.		
Meringues	100 (C/B)	90	2-3 hours.		
Baked egg custard	160 (C/B)	150	45-60 minutes.		
Baked sponge pudding	180 (C/B)	170	40-45 minutes.		
Milk pudding	140-150 (C/B)	130-140	2 to 3 hours.		
Bread	210 (C)	200	20-30 minutes.		<i>If cooking a two tier load, the trays should be interchanged approximately halfway through the cooking time.</i>
Fish					
Fanned Grilling					
Fillet	190 (C/B)	190 (C/B)	15-20 minutes.		
Whole	190 (C/B)	190 (C/B)	15-20 minutes per 500g.		
Steak	190 (C/B)	190 (C/B)	Steaks according to thickness.		

5. Cleaning Your Cooker

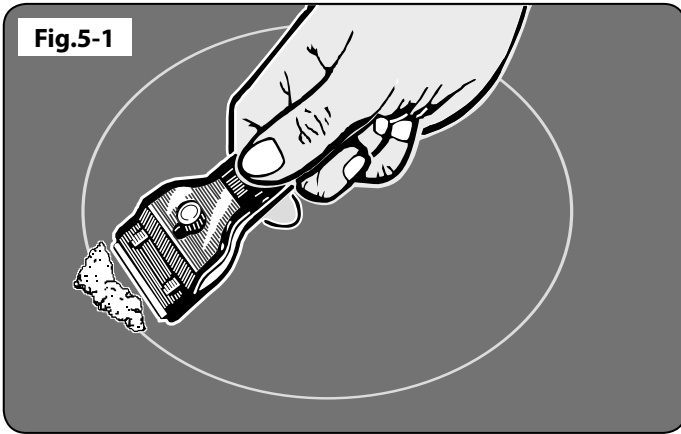

Isolate the electricity supply before carrying out any major cleaning. Allow the cooker to cool.

- ⚠ **NEVER use paint solvents, washing soda, caustic cleaners, biological powders, bleach, chlorine based bleach cleaners, coarse abrasives or salt.**
- ⚠ **DO NOT mix different cleaning products – they may react together with hazardous results.**
- ⚠ **Avoid using any abrasive cleaners including cream cleaners. For best results, use a liquid detergent.**
- ⚠ **All parts of the cooker can be cleaned with hot soapy water – but take care that no surplus water seeps into the appliance.**

Remember to switch the electricity supply back on before reusing the cooker.

Hob

Daily Care

First of all make sure that all heat indicator lights are off and that the cooking surface is cool. Apply a small dab of ceramic cleaning cream in the centre of each area to be cleaned. Dampen a clean paper towel and work the cream onto the cooking surface. As a final step, wipe the cooking surface with a clean, dry paper towel.

Cleaning Spills

For spills and boil-overs that occur while cooking, turn the unit off and wipe the area surrounding the hot zone with a clean paper towel. If a spill (other than a sugary substance) is on the hot zone, do not clean until the unit has completely cooled down, and then follow the instructions below (*'Cleaning Burned-on Spills'*).

If you accidentally melt anything on the surface, or if you spill foods with a high sugar content (preserves, tomato sauce, fruit juice, etc.), remove the spill **IMMEDIATELY** with a razor scraper, while the unit is still hot.

IMPORTANT: Use an oven glove to protect your hand from potential burns.

Scrape the major spill or melted material from the cooking zone and push into a cold area. Then, turn the unit 'OFF' and allow it to cool before cleaning further. After the cooking surface cools down and the heat indicator lights go off, follow the *'Daily Care'* procedure outlined above.

Cleaning Burned-on Spills

Make sure that the heat indicator lights are off and that the hob is cool. Remove the excess burned-on substance with a single-edged razor scraper. Hold the scraper at an angle of about 30° to the surface and then scrape off the burned-on matter (**Fig.5-1**).

Glide-out Grill

⚠ Before you remove any of the grill parts for cleaning, make sure that they are cool, or use oven gloves.

Wash the grill pan and trivet washed in hot soapy water. Alternatively, wash the grill pan in a dishwasher.

After grilling meats or any foods that soil, leave to soak for a few minutes in the sink immediately after use. Stubborn particles may be removed from the trivet by using a nylon brush.

Removing and Refitting the Grill Pan and Support Frame

Pull the grill pan forwards (**Fig.5-2**) and lift it clear of the support frame.

The support frame is held to the side rails by two clips on each side (**Fig.5-3**). For each side, support the side rail with one hand and with the other hand lift the frame up and out of the side clips (**Fig.5-4**).

For safety, push the grill tray back into the grill chamber.

If you need to remove the side rails to allow cleaning of the grill chamber, you can unhook them from the grill chamber sides (**Fig.5-5**) and wipe the sides clean with a soft cloth and mild detergent.

DO NOT put the side runners in a dishwasher.

Once you have finished, hook the side rails back onto the sides of the chamber. To refit the frame, pull the side rails forwards and for each side in turn, support the side rail while pressing the frame down into the side clips.

Replace the grill pan.

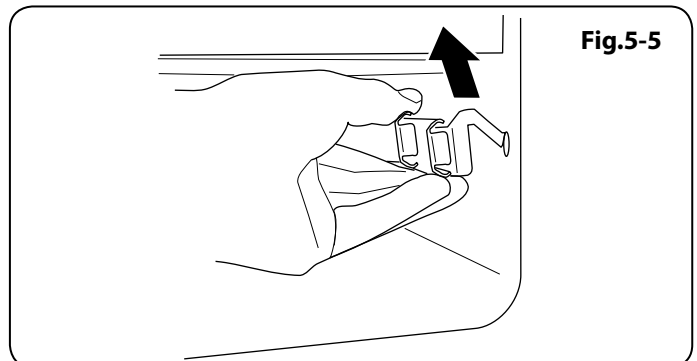
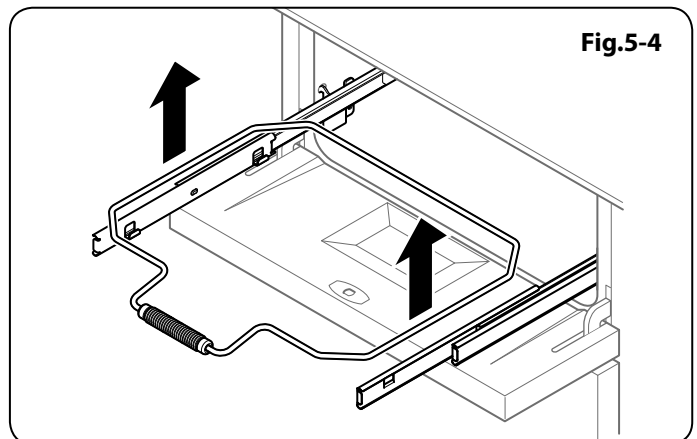
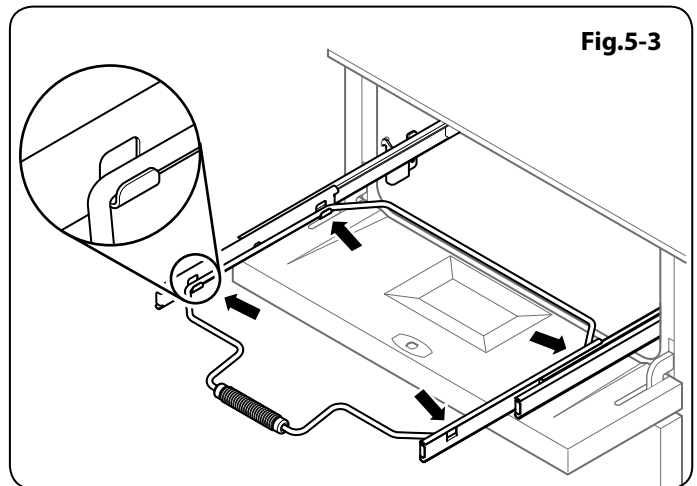
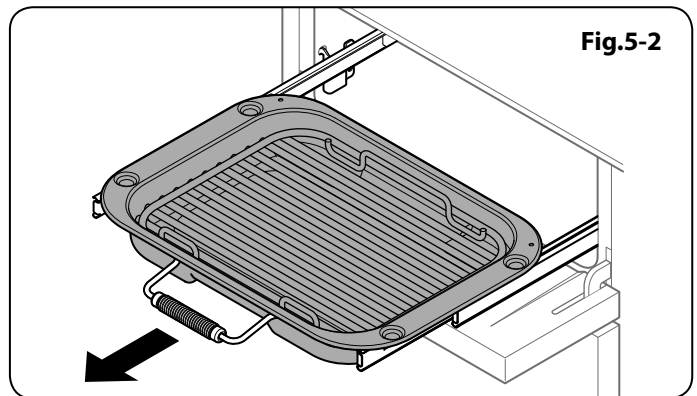
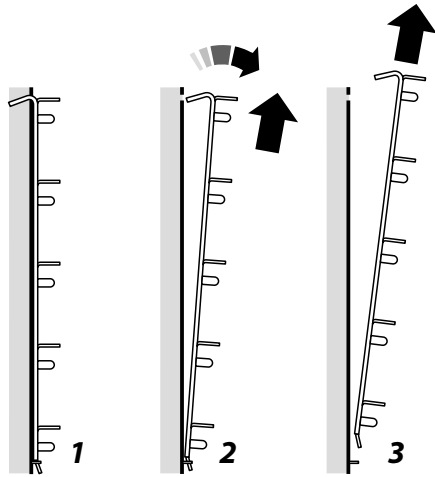

Fig.5-6



Control Panel and Oven Doors

The control panel and control knobs should only be cleaned with a soft cloth wrung out in clean hot soapy water – but take care that no surplus water seeps into the appliance. Wipe with a clean dampened cloth then polish with a dry cloth.

The oven doors should only be cleaned with a soft cloth wrung out in clean hot soapy water.

Ovens

'Cook & Clean' Panels

The ovens have side 'Cook & Clean' panels which have been coated with a special enamel that partly cleans itself. This does not stop all marks on the lining, but helps to reduce the amount of manual cleaning needed.

These panels work better above 200°C. If you do most of your cooking below this temperature, occasionally remove the panels and wipe with a lint free cloth and hot soapy water. The panels should then be dried and replaced and the oven heated at 200°C for about one hour. This will ensure that the panels are working effectively.

⚠ DO NOT use steel wool (or any other materials that will scratch the surface).

⚠ DO NOT use oven cleaning pads.

The Oven Shelf Supports

The shelf supports on the oven sides can be removed for cleaning.

Removing the Oven Shelf Supports

Remove the oven shelves. Pull the top of the shelf support up and away from the oven side and then lift the support away from the locating bracket at the bottom of the oven side (Fig.5-6).

Refitting the Oven Shelf Supports

To refit the side support. Locate the tag at the bottom of the support into the slot in the locating bracket in the oven side (Fig.5-7). Now locate the tops of the side arms in the holes at the top and gently push down.

Fig.5-7

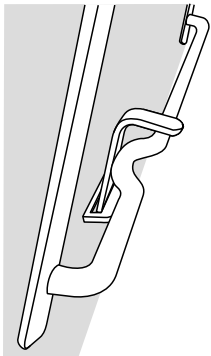
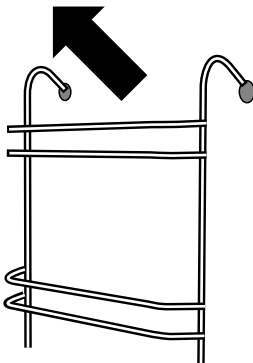

Fig.5-8



The Tall Oven

To clean the oven sides, slide out the shelves, unhook the supports from the oven sides and lift out (Fig.5-8).

Cleaning Table

Cleaners listed (**Table 5-1**) are available from supermarkets or electrical retailers as stated.

For enamelled surfaces use a cleaner that is approved for use on vitreous enamel.

Regular cleaning is recommended. For easier cleaning, wipe up any spillages immediately.

Hotplate		
Part	Finish	Recommended Cleaning Method
Hob top	Enamel or stainless steel	Hot soapy water, soft cloth. Any stubborn stains remove gently with a nylon scourer.
Ceramic/Induction hob	Toughened glass	Hot soapy water; cream cleaner/scourer if necessary.
Griddle plate (some models only)	Non-stick surface	Allow to cool. Wash in hot soapy water. Do not use abrasive cleaners/scourers. Dishwasher.
Warming zone (some models only)	Toughened glass	Hot soapy water, cream cleaner/scourer if necessary.
Outside of Cooker		
Part	Finish	Recommended Cleaning Method
Door, door surround and storage drawer exterior	Enamel or paint	Hot soapy water, soft cloth. Any stubborn stains, remove gently with a liquid detergent.
	Stainless steel	E-cloth or microfibre all-purpose cloth (supermarket).
Sides and plinth	Painted surface	Hot soapy water, soft cloth.
Splashback/rear grille	Enamel or stainless steel	Hot soapy water, soft cloth. Cream cleaner, with care, if necessary.
Control panel	Paint, enamel or stainless steel	Warm soapy water. Do not use abrasive cleaners on lettering.
Control knobs/handles & trims	Plastic/chrome, aluminium, copper or lacquered brass	Warm soapy water, soft cloth.
	Brass	Brass polish.
Oven door glass/glass lid	Toughened glass	Hot soapy water, cream cleaner/scourer if necessary.
Oven and Grill		
Part	Finish	Recommended Cleaning Method
Sides, floor & roof of oven NOT 'COOK & CLEAN' OVEN PANELS (see below)	Enamel	Any proprietary oven cleaner that is suitable for enamel. CAUTION: CORROSIVE/CAUSTIC OVEN CLEANERS: FOLLOW MANUFACTURER'S INSTRUCTIONS. Do not allow contact with the oven elements.
'Cook & Clean' oven panels (some models only)	Special enamel that partly cleans itself	This surface cleans itself at 200°C and above, or the panels can be removed and washed with hot soapy water and a nylon brush.
Oven shelves, Handyrack, grill trivet, Handygrill rack	Chrome	An oven interior cleaner that is suitable for chrome. Soap filled pad. Dishwasher.
Grill pan/meat tin (some models only)	Enamel	Hot soapy water. Soap filled pad. Dishwasher.

Table 5-1

6. Troubleshooting

⚠ Interference with and repairs to the hob MUST NOT be carried out by unqualified persons. Do not try to repair the hob as this may result in injury and damage to the hob. Please arrange for repair by a suitably competent person.

Note: The induction hob is able to self-diagnose a number of problems and can show this information to the user via the hob control display. Error codes may be displayed if your hob has developed a fault.

If your appliance reports an error or is not working, you may be able to correct the fault by consulting the following.

Error code E2 is displayed

The electronic unit is too hot. Please check the installation of the cooker, making sure that there is sufficient ventilation. In extreme cases, if a cooking utensil has been allowed to boil dry this error code may also be displayed. If in doubt please contact your installer or a qualified repair engineer.

No display operation

Over voltage or loss of supply voltage to the cooker. If in doubt please contact your installer or a qualified repair engineer.

Error code U400 is displayed

The cooker has been incorrectly connected. The control will switch off after approximately 1 second and the error code will be permanently displayed.

Consult your installer or a qualified repair engineer.

Error code Er followed by a number is displayed

The appliance has developed an internal technical fault that cannot be rectified by the user.

Consult your installer or a qualified repair engineer.

The fuse blows or the RCD trips regularly

Please contact your installer or a qualified repair engineer.

The hob will not switch on

Has the wiring system in the house blown a fuse or tripped an RCD?

Has the hob been correctly connected to the mains supply?

Has the child lock been activated? Please refer to the child lock section for details of this function.

The induction hob is noisy

When using the induction hob there may be some 'noise' emitted from the pan. This is normal and may be most noticeable when cooking on high power settings or if 5 pans are used simultaneously. The type of pan may also contribute to induction 'noise'.

The cooling fan

The induction hob incorporates a cooling fan. This cooling fan is active when either the grill or ovens are on. Under certain conditions, the cooling fan may remain active when the grill or ovens are switched off. This is normal and the fan will switch off automatically.

A crack has appeared in the hob surface

Disconnect the cooker immediately from the power supply and arrange for its repair. Do not use the cooker until after the repair.

My hob is scratched

Always use the cleaning methods recommended in this guide, and make sure that the pan bottoms are smooth and clean.

Marks from mineral deposits from water or food can be removed with a cleaning cream. However, tiny scratches are not removable but will become less visible in time as a result of cleaning.

The oven fan is noisy

The sound of the oven fan may change as the oven heats up – this is perfectly normal.

Grill not cooking properly

Are you using the pan and trivet supplied with the cooker? Is the pan being used on the runners, not the floor of the compartment? Is the grill tray pushed back fully to the 'back stop' position?

The knobs get hot when I use the oven or grill. Can I avoid this?

Yes, this is caused by heat rising from the oven or the grill, and heating them up. Do not leave the oven door open. Make sure that the grill pan is pushed right back to the 'back stop' when grilling.

Always grill with the grill compartment door open.

If there is an installation problem and I don't get my original installer to come back to fix it, who pays?

You do. Service organisations will charge for their call-outs if they are correcting work carried out by your original installer. Therefore, it's in your own interest to keep track of this installer so that you can contact them as required.

Food is cooking too slowly, too quickly, or burning

Cooking times may differ from your previous oven.

Check that you are using the recommended temperatures and shelf positions – see the oven cooking guide.

You can then adjust the settings according to your own individual tastes.

The oven is not cooking evenly

Do not use a baking tray with dimensions larger than those specified in the section on 'General Oven Tips'.

If you are cooking a large item, be prepared to turn it round during cooking.

If two shelves are used, check that space has been left for the heat to circulate. When a baking tray is put into the oven, make sure that it is placed centrally on the shelf.

Check that the door seal is not damaged and that the door catch is adjusted so that the door is held firmly against the seal.

A dish of water when placed on the shelf should be the same depth all over. (For example, if it is deeper at the back, then the back of the cooker should be raised up or the front lowered.) If the cooker is not level, arrange for your supplier to level it for you.

Oven temperature getting hotter as the cooker gets older

If turning the temperature down using the oven control knob has not worked, or has only worked for a short time, then you may need a new thermostat. This should be fitted by a service person.

The oven door is misaligned

The bottom hinge of the left-hand oven door can be adjusted to alter the angle of the door (**Fig.6-1**). Loosen the bottom hinge fixing screws and use the notch and a flat bladed screwdriver to move the position of the hinge to set the hinge position (**Fig.6-2**).

Retighten the hinge screws.

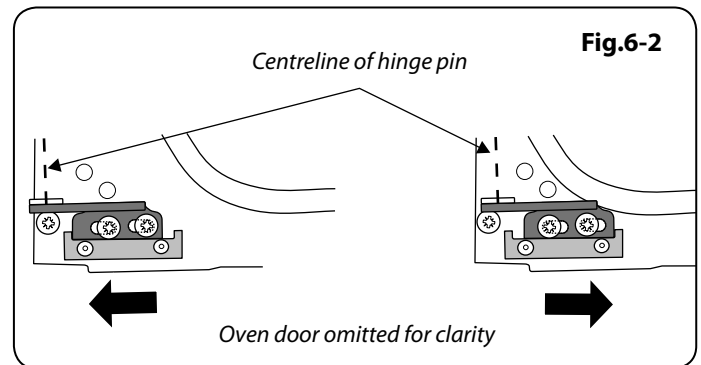
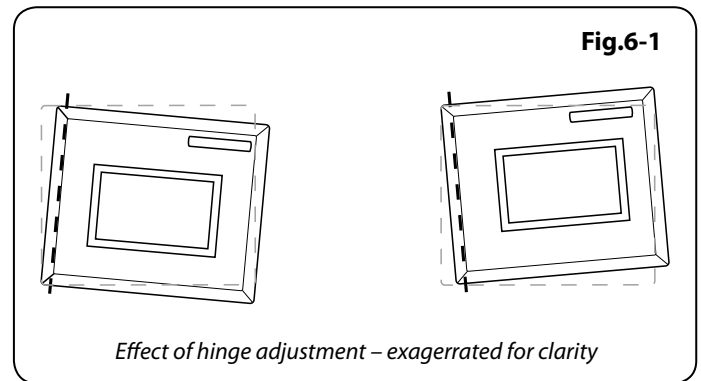

INSTALLATION

Check the appliance is electrically safe when you have finished.

7. Installation

Dear Installer

Before you start your installation, please complete the details below, so that, if your customer has a problem relating to your installation, they will be able to contact you easily.

Installer's Name
Installer's Company
Installer's Telephone Number
Appliance Serial Number

Safety Requirements and Regulations

You must be aware of the following safety requirements & regulations.

- ⚠ This cooker must be installed in accordance with the relevant instructions in this booklet, with the relevant national and local regulations, and with the local electricity supply companies' requirements.**
- ⚠ The appliance must be installed in accordance with the regulations in force and only in a well-ventilated space.**
- ⚠ Read the instructions before installing or using this appliance.**
- ⚠ This appliance is designed for domestic cooking only. Use for any other purpose could invalidate any warranty or liability claim.**

Provision of Ventilation

This appliance is not connected to a combustion products evacuation device. Therefore, particular attention must be given to the relevant requirements regarding ventilation.

All rooms require a window that can be opened, or equivalent, while some rooms require a permanent vent in addition to the window.

Location of Cooker

The cooker may be installed in a kitchen/kitchen diner but NOT in a room containing a bath or shower.

You will need the following equipment to complete the cooker installation satisfactorily:

- Multimeter (for electrical checks).
- Allen keys (provided in pack).

You will also need the following tools:

1. Steel tape measure
2. Cross-head screwdriver
3. Flat head screwdriver
4. Spirit level
5. 13 mm spanner or socket wrench

Checking the Parts:

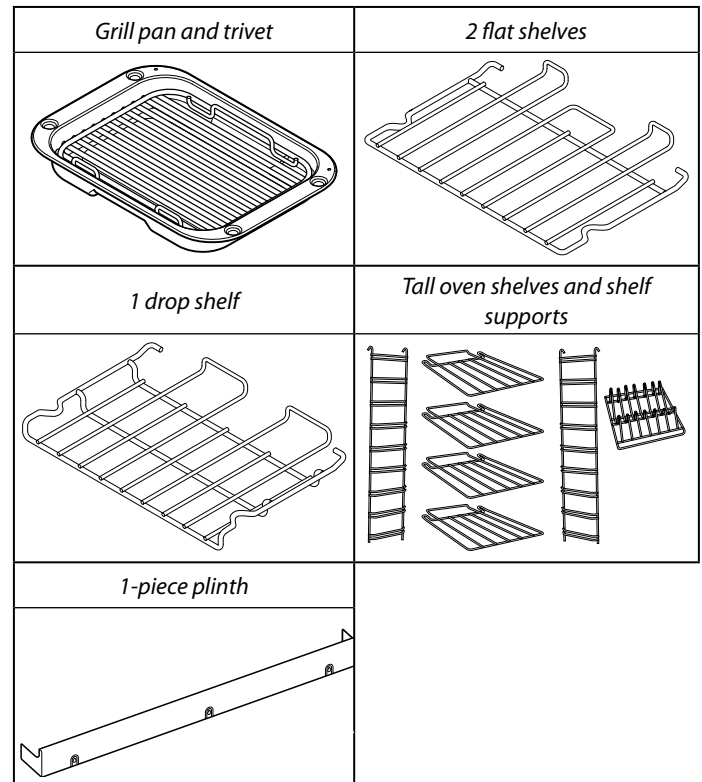

INSTALLATION

Check the appliance is electrically safe when you have finished.

Positioning the Cooker

Fig.7-1 and **Fig.7-2** show the minimum recommended distance from the cooker to nearby surfaces.

The cooker should not be placed on a base.

Above hotplate surround should be level with, or above, any adjacent work surface.

A gap of 75 mm should be left between each side of the cooker **ABOVE** the hotplate level and any adjacent vertical surface.

For non-combustible surfaces (such as unpainted metal or ceramic tiles), this can be reduced to 25 mm.

A minimum space of 800 mm is required between the top of the hotplate and a horizontal combustible surface.

* Any cookerhood should be installed in accordance with the hood manufacturer's instructions.

**Any splashback must be fitted in accordance with the manufacturers instructions. Allowance should be made for the flue trim, which is fitted to the cooker hob.

Surfaces of furniture and walls at the sides and rear of the appliance should be heat, splash and steam resistant. Certain types of vinyl or laminate kitchen furniture are particularly prone to heat damage and discolouration.

We cannot accept responsibility for damage caused by normal use of the cooker to any material that de-laminates or discolours at temperatures less than 65°C above room temperature.

We recommend a gap of 910 mm between units to allow for moving the cooker. Do not box the cooker in – it must be possible to move the cooker in and out for cleaning and servicing.

If the cooker is near a corner of the kitchen, a clearance of 130 mm is required to allow the oven doors to open (**Fig.7-3**). The actual opening of the doors is slightly less but this allows for some protection of your hand as you open the door.

Moving the Cooker

⚠ On no account try and move the cooker while it is plugged into the electricity supply.

⚠ The cooker is very heavy, so take great care.

We recommend that two people manoeuvre the cooker. Make sure that the floor covering is firmly fixed, or removed, to prevent it being disturbed when moving the cooker around.

To help you, there are two levelling rollers at the back, and two screw-down levelling feet at the front.

Remove the polystyrene base pack. From the front, tilt the cooker forward and remove the front half of the polystyrene base (**Fig.7-4**). Repeat from the back and remove the rear half of the polystyrene base.

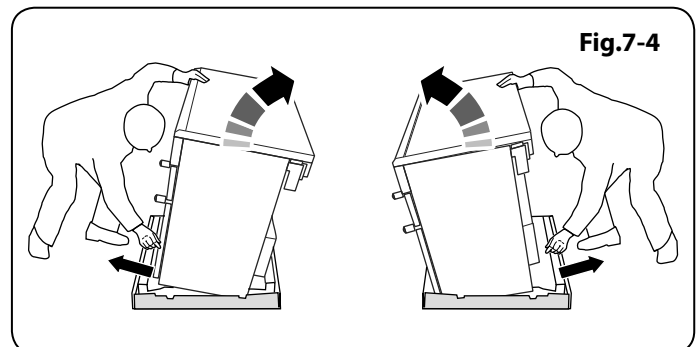
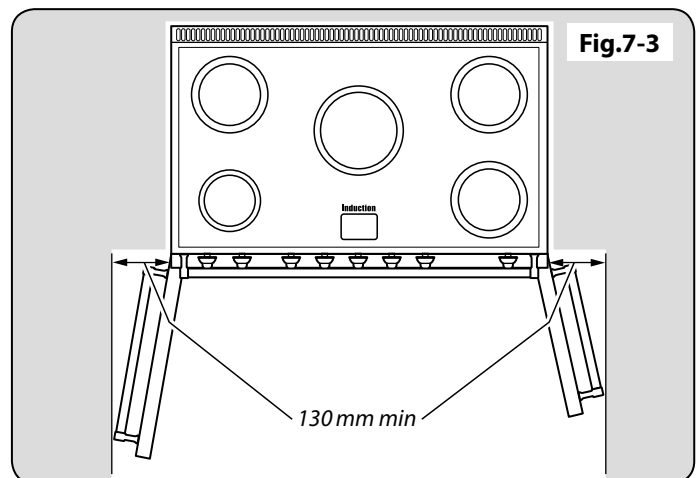
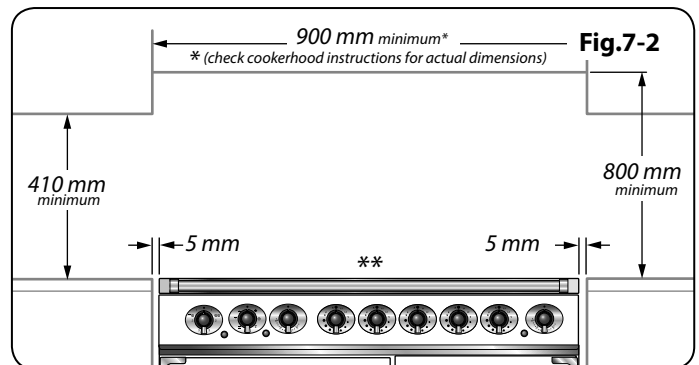
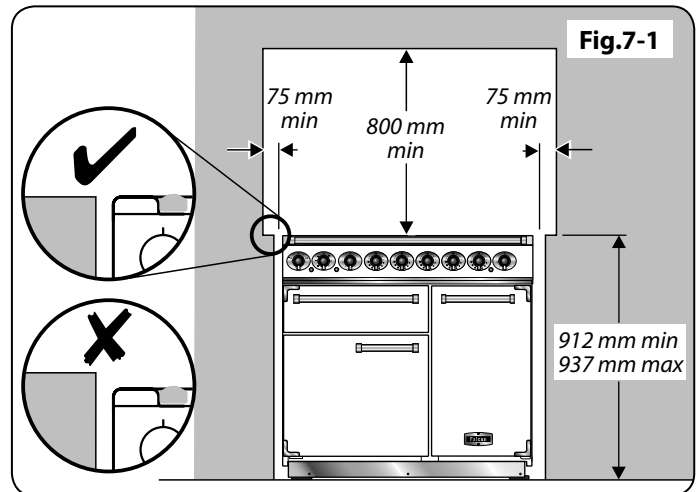

INSTALLATION

Check the appliance is electrically safe when you have finished.

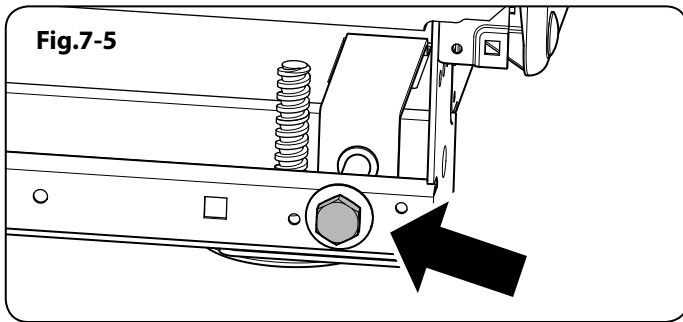

Lowering the Two Rear Rollers

To adjust the height of the rear of the cooker, first fit a 13 mm spanner or socket wrench onto the hexagonal adjusting nut (**Fig.7-5**). Rotate the nut – clockwise to raise – counter-clockwise to lower.

Make 10 complete (360°) turns clockwise.

Make sure you lower BOTH REAR ROLLERS.

Completing the Move

Unfold the rear edge of the pack base tray. Open the grill door and right-hand oven door so that you can get a good grip on the bottom of the fascia panel as you move the oven (**Fig.7-6**).

Carefully push the cooker backwards off the pack base. Remove the pack base tray.

Position the cooker close to its final position, leaving just enough space to get behind it.

⚠ DO NOT use the door handles or control knobs to manoeuvre the cooker.

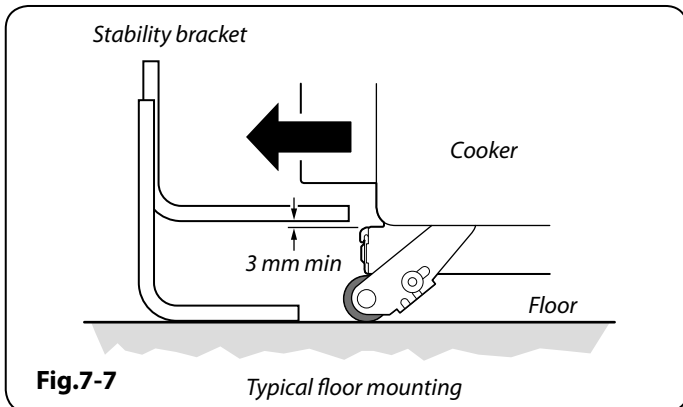
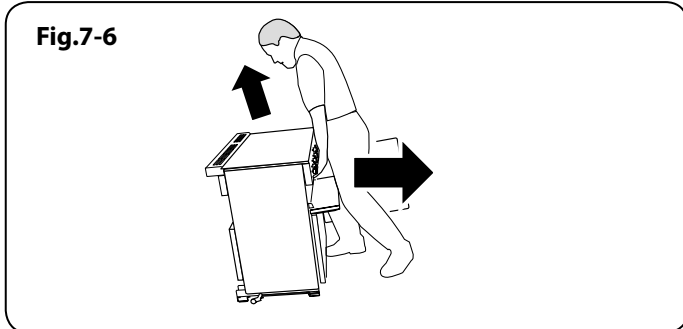

Fitting the Stability Bracket

Suitable stability devices are shown in **Fig.7-7** and **Fig.7-8**.

If you are using a stability bracket (**Fig.7-7** and **Fig.7-8**), then adjust the bracket to give the smallest practicable clearance between the bracket and the engagement slot in the rear of the cooker.

Fit the bracket so that it engages as far as possible over the chassis of the cooker.

Repositioning the Cooker Following Connection

If you need to move the cooker once it has been connected then you need to unplug it and, having gripped under the fascia panel and lifted the front of the cooker slightly (**Fig.7-6**), you need to check behind the cooker to make sure that the electricity cable is not caught.

As you progress, make sure that the electricity cable always has sufficient slack to allow the cooker to move.

When you replace the cooker, again check behind to make sure that the electricity cable is not caught or trapped.

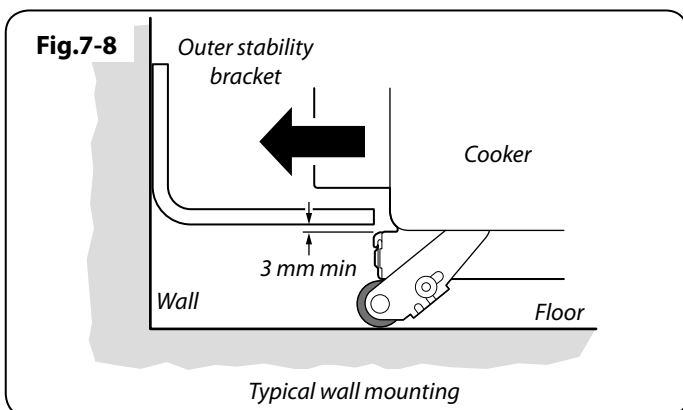

Levelling

You are recommended to use a spirit level on a shelf in one of the ovens to check for level. Place the cooker in its intended position taking care not to twist it within the gap between the kitchen units as damage may occur to the cooker or the units. The front feet and rear rollers can be adjusted to level the cooker. To adjust the height of the rear of the cooker, use a 13 mm spanner or socket wrench to turn the adjusting nuts at the front bottom corners of the cooker.

To set the front turn the feet bases to raise or lower.

INSTALLATION

Check the appliance is electrically safe when you have finished.

Electrical Connection

The cooker must be installed by a qualified electrician, in accordance with all relevant British Standards/Codes of Practice (in particular BS 7671), or with the relevant national and local regulations.

Current Operated Earth Leakage Breakers

The combined use of your cooker and other domestic appliances may cause nuisance tripping, so we recommend that the cooker is protected on an individual RCD (Residual Current Device) or RCBO (Residual Current Breaker with Overload).

IF IN DOUBT, PLEASE CONSULT A SUITABLY QUALIFIED ELECTRICIAN.

Note: The cooker must be connected to the correct electrical supply as stated on the voltage label on the cooker, through a suitable cooker control unit incorporating a double pole switch, having a contact separation of at least 3 mm in all poles.

⚠ The cooker MUST NOT be connected to an ordinary domestic power point.

Access to the mains terminal is gained by removing the electrical terminal cover box on the back panel. Connect the mains cable to the correct terminals for your electrical supply type (**Fig.7-9** and **Fig.7-10**). Check that the links are correctly fitted and that the terminal screws are tight.

Secure the mains cable using the cable clamp.

Final Checks

Hotplate Check

Check each cooking zone in turn. Be sure to use pans of the correct size and material.

Grill Check

Turn on the grill control and check that the grill heats up.

Oven Check

Turn on the ovens – check that the oven fans start to turn and that the ovens start to heat up.

Fitting the Plinth

Remove the 3 screws along the bottom edge of the cooker. Hold the plinth in place and refit the 3 screws.

Customer Care

Installer: Please complete your details in this guide, inform the user how to operate the cooker and hand over the instructions.

Thank you.

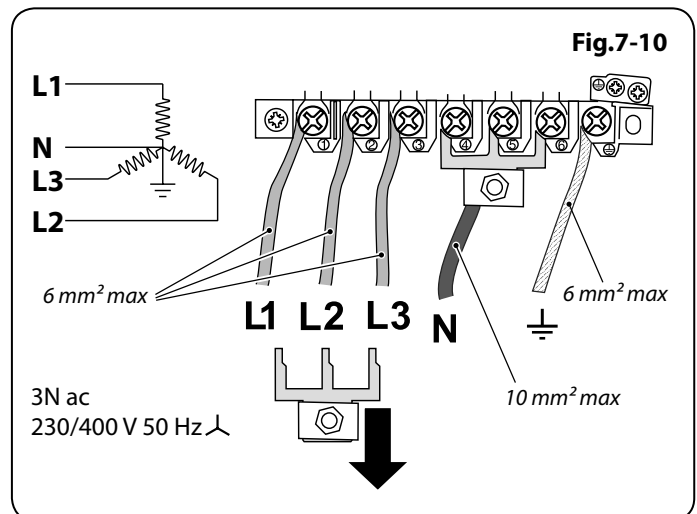
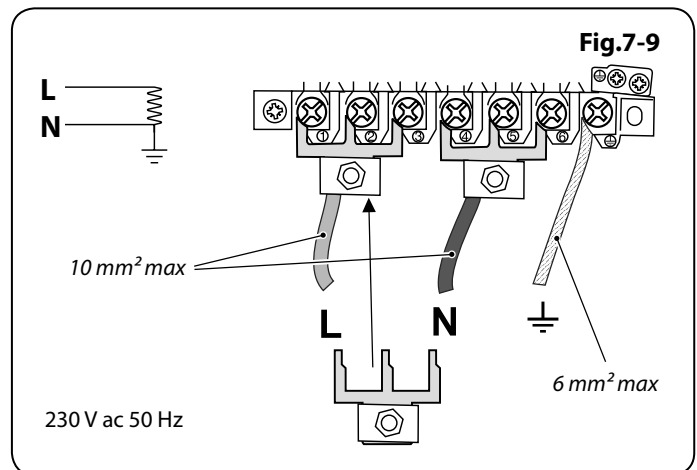

8. Circuit Diagrams

Circuit Diagram: Hob

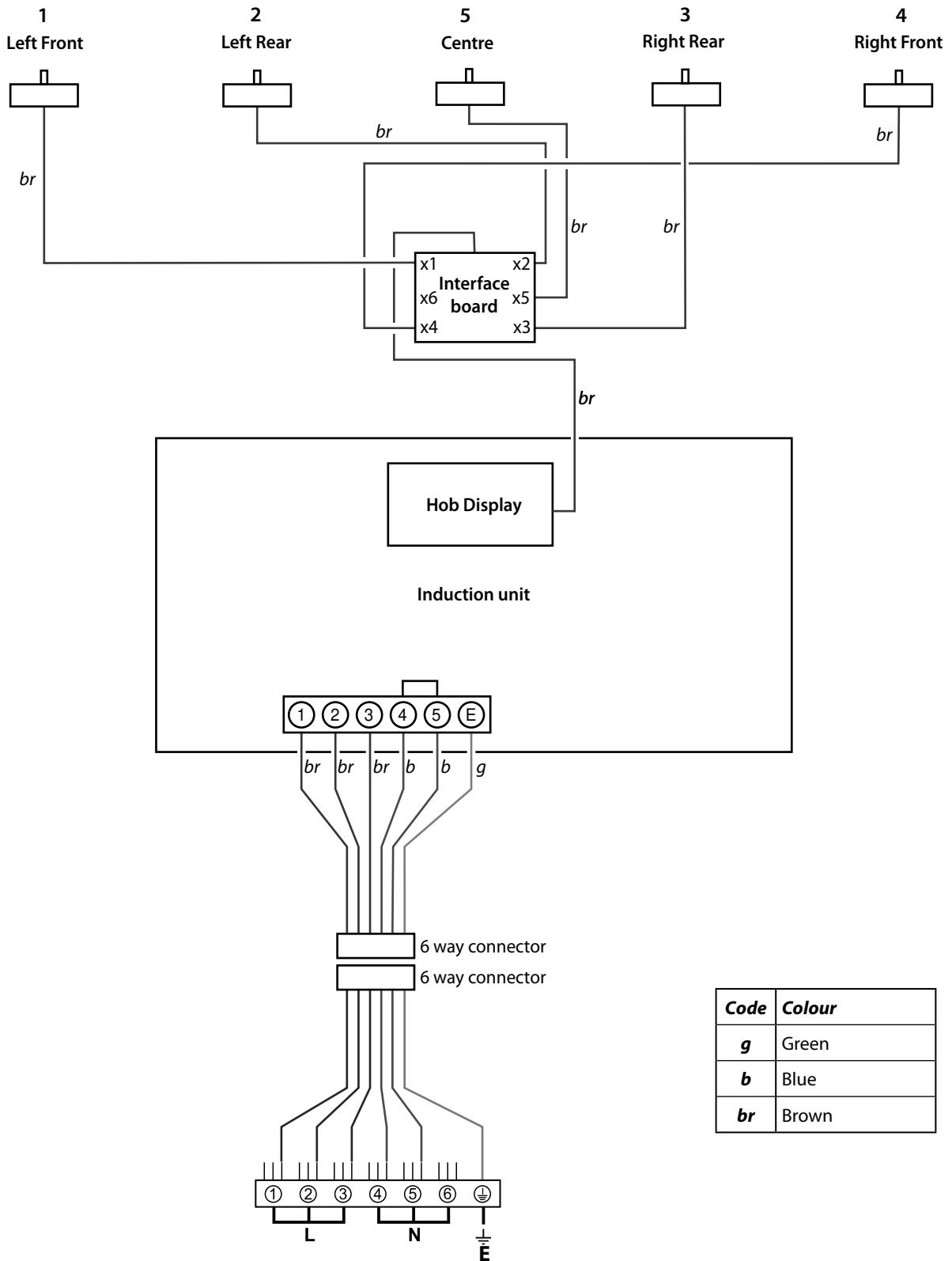

Circuit Diagram: Oven

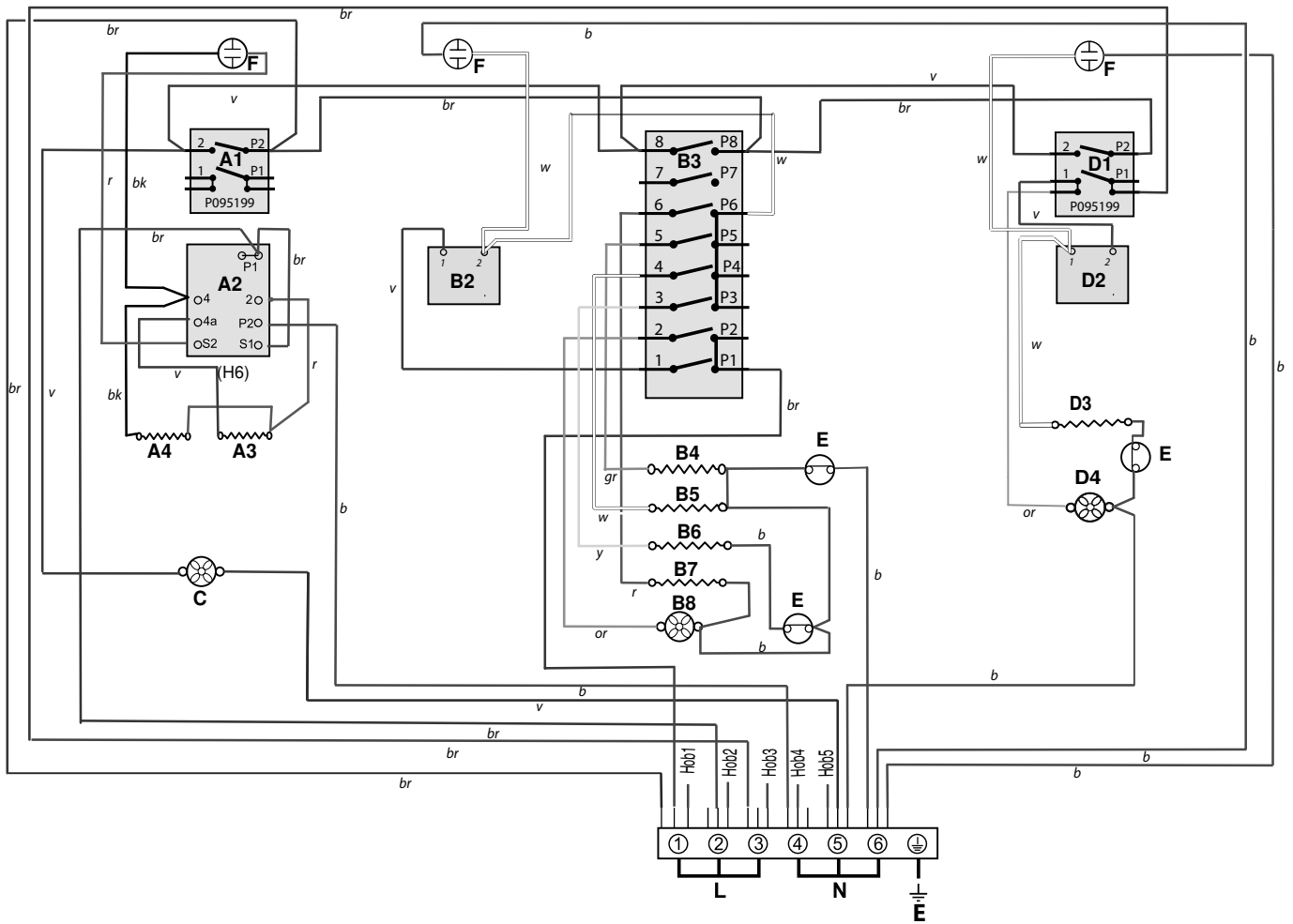

Key

The connections shown in the circuit diagram are for single-phase. The ratings are for 230V 50 Hz.

Code	Description
A1	Grill front switch
A2	Grill control
A3	Grill left-hand element
A4	Grill right-hand element
B2	Multi-function oven thermostat
B3	Multi-function oven function switch
B4	Multi-function oven top element
B5	Multi-function oven browning element
B6	Multi-function oven fan element
B7	Multi-function oven base element

Code	Description
B8	Multi-function oven fan
C	Cooling fan
D1	Right-hand oven front switch
D2	Right-hand oven thermostat
D3	Right-hand oven fan element
D4	Right-hand oven fan
E	Thermal cut-out
F	Neons

Code	Colour
b	Blue
br	Brown
bl	Black
or	Orange
r	Red
v	Violet
w	White
y	Yellow
g/y	Green/yellow
gr	Grey

9. Technical Data

INSTALLER: Please leave these instructions with the user.

DATA BADGE LOCATION: Cooker back, serial number repeater badge below door opening.

COUNTRIES OF DESTINATION: GB, IE, FR, DE, NL, SE, BE, AT, CH.

Connections

Electric	230 / 400V 50Hz
----------	-----------------

Dimensions

Total height	Min 912 mm	Max 937 mm
Total width	900 mm	
Total depth	600 mm (to fascia); 670 mm (over handles)	
Minimum height above cooker	800 mm	

Refer to 'Positioning the Cooker'.

Ratings

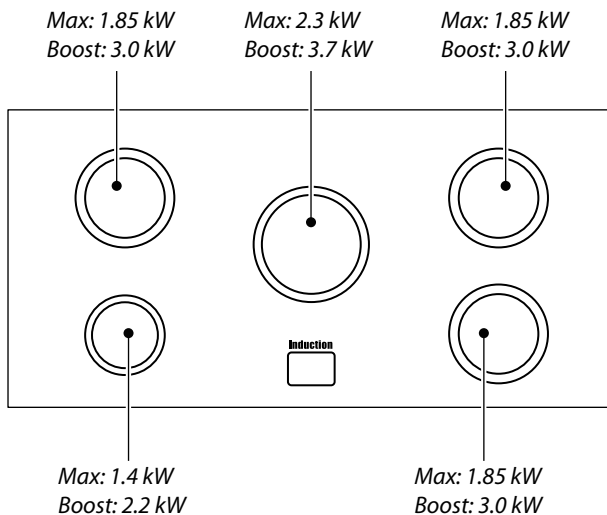

Ovens	Left-hand Oven	Right-hand Oven
	Multi-function	Forced Air Convection
Maximum power output @ 230v 50Hz	2.5 kW	2.5 kW
Energy efficiency class on a scale of A (more efficient) to G (less efficient)	A	A
Energy consumption based on standard load	0.95 kWh	0.99 kWh
Usable volume (litres)	78	66
Size	Large	Large
Time to cook standard load	41 minutes	48 minutes
Surface area of the grid	1400 cm ²	1056 cm ²

Grill	2.3 kW
-------	--------

Maximum total electric load at 230V 50 Hz (approximate total including oven lights, oven fan, etc.): 18.4 kW.

10. Warranty/After Sales Service

If consultation or technical assistance is needed, please provide the local authorised service agent with the purchase invoice and the product code/serial number.

This information is on the appliance data badge. This is located inside the drawer cavity base. For removal of the drawer see the '*Overview / Storage*' section.

The 3 years free maintenance for the operation of the appliance started from the date of purchase of this product.

Any cosmetic damage to the appliance must be reported within 90 days of delivery.

For in-warranty service please call: **0845 6035312**.

For general enquiries please call: **0870 7895107**.

If You Have a Problem

In the unlikely event that you have a problem with your appliance, please refer to the rest of this booklet, especially the '*Troubleshooting*' section, first to check that you are using the appliance correctly.

If you are still having difficulty, contact your retailer.

Notes

If your appliance is outside the 3 year warranty period, our service provider may charge for this visit.

If you request an engineer to visit and the fault is not the responsibility of the manufacturer, our service provider reserves the right to make a charge.

Appointments not kept by you may be subject to a charge.

Out of Warranty

We recommend that our appliances are serviced regularly throughout their life to maintain the best performance and efficiency.

Any servicing work should only be carried out by technically competent and suitably qualified personnel.

Spare Parts

To maintain optimum and safe performance, only use genuine parts. Do not use reconditioned or unauthorised controls. Contact your retailer.

Name of Appliance & Colour*				
Appliance Serial Number*				
Fuel Type*	Natural Gas	<input type="checkbox"/>	LP Gas	<input type="checkbox"/>
	Dual Fuel	<input type="checkbox"/>	Electric	<input type="checkbox"/>
Retailer's Name & Address				
Date of Purchase				
Installer's Name & Address				
Installer's Telephone Number				
Date of Installation				

* This information is on the appliance data badge – look in the appliance instructions to find out where the data badge is located.

CONSUMER SERVICE

If you have any product enquiries, or in the event of a problem with your appliance once it has been installed, please telephone 0870 789 5107.

CONSUMER SERVICE LINES OPEN:

Monday to Thursday 8am–6pm
 Friday 8am–5pm
 Saturday 9am–1pm

WARRANTY

Your manufacturer warranty covers goods of our own brand for defective workmanship and materials for a period of 3 year from the date of purchase. This warranty covers mechanical breakdown and proven cosmetic and manufacturing defects.

To register for this guarantee simply fill in and return the FREEPOST registration form provided. Alternatively call free on 0800 694 4170, quoting reference FAGX91AN or register online at www.falconappliances.co.uk

Any damage, blemishes or chips identified upon receipt of the product must be reported within 90 days ñ proof of purchase may be required to establish validity. Scratches on the surface of ceramic hobs must be reported within 14 days. Scratches caused by usage are not covered. Accidental damage is not covered by the manufacturer's warranty.

For warranty compliance, the requirements are that the appliance:

- Has been correctly installed in accordance with current legislation, relevant British and European Standards and Codes of Practice, by a suitably competent person registered with Gas Safe or equivalent body and, where applicable, a qualified electrician.
- Has been used solely for domestic cooking purposes.
- Is in use in the UK*, has not been taken abroad as a personal export. (In the Republic of Ireland conditions may vary, so consult your retailer.)
- Is not second-hand or a refurbished appliance. The manufacturer's warranty is not transferable.
- Has not been subject to misuse, accidental damage or modification, and has not deteriorated due to normal domestic wear and tear, and the manufacturer's recommendations concerning cleaning materials have been followed.
- Has not been repaired by persons or organisations other than those authorised to act on behalf of AGA Rangemaster.

Exceptions:

- Items not included under the free 3 year guarantee include pan supports, griddles, wok rings, baking trays, grill pans, trivets, filters, light bulbs and other consumable accessories.
- Any damage caused other than through normal use.
- Breakdowns associated with cooking spillage.
- Cosmetic deterioration deemed to be normal wear and tear.

This warranty is in addition to your Statutory Rights.

- * Only certain models can be adapted for use with Mains Gas supplied in the Channel Islands and Isle of Man.

OUT OF WARRANTY

We recommend that Falcon appliances are serviced regularly throughout their life to maintain optimum performance and efficiency. Service work should only be carried out by technically competent and suitably qualified personnel.

For your own safety, always make sure that work is carried out by a Gas Safe registered engineer for gas appliances or an approved electrician for electrical models.

For a competitive quote and to arrange for a Falcon approved engineer to attend, call Consumer Services on: 0870 789 5107.

SPARE PARTS

To maintain optimum and safe performance, we recommend that only genuine Falcon spare parts are used. These are available from most major spares stockists, including ourselves.

Contact Consumer Services on 0870 789 5107, who will be happy to help.

STANDARDS

Falcon cookers are designed and manufactured to a recognised international quality standard, which meets the requirements of BS EN ISO 9001, BS EN ISO 14001 and OHSAS 18001 for continually improving environmental procedures.

Falcon cookers comply with the essential requirements of the appropriate European Directives, and carry the CE mark.



DIVERTIMENTI

For over 45 years
DIVERTIMENTI, Falcon's
sister company, has
been the ultimate destination
for food lovers and serious
chefs alike. With its vast array
of cookware, tableware and
kitchenware, DIVERTIMENTI
caters to all your culinary needs.
With over 4500 items on the
DIVERTIMENTI
website www.divertimenti.co.uk



Falcon Appliances
Clarence Street
Royal Leamington Spa
Warwickshire
CV31 2AD
Tel 0870 755 6490
Fax 0192 631 1032

Email consumers@falconappliances.co.uk
www.falconappliances.co.uk
Trade Enquiries 0115 946 6143
Email sales@falconappliances.co.uk

Registered in England and Wales. Registration No. 354715 Registered Office: Juno Drive, Leamington Spa, Warwickshire, CV31 3RG

Falcon continuously seeks improvements in specification, design and production of products and thus, alterations take place periodically. Whilst every effort is made to produce up-to-date literature, this booklet should not be regarded as an infallible guide to current specification, nor does it constitute an offer for the sale of any particular appliance.

